

REAR-RACK

SPIDER / COUPÉ

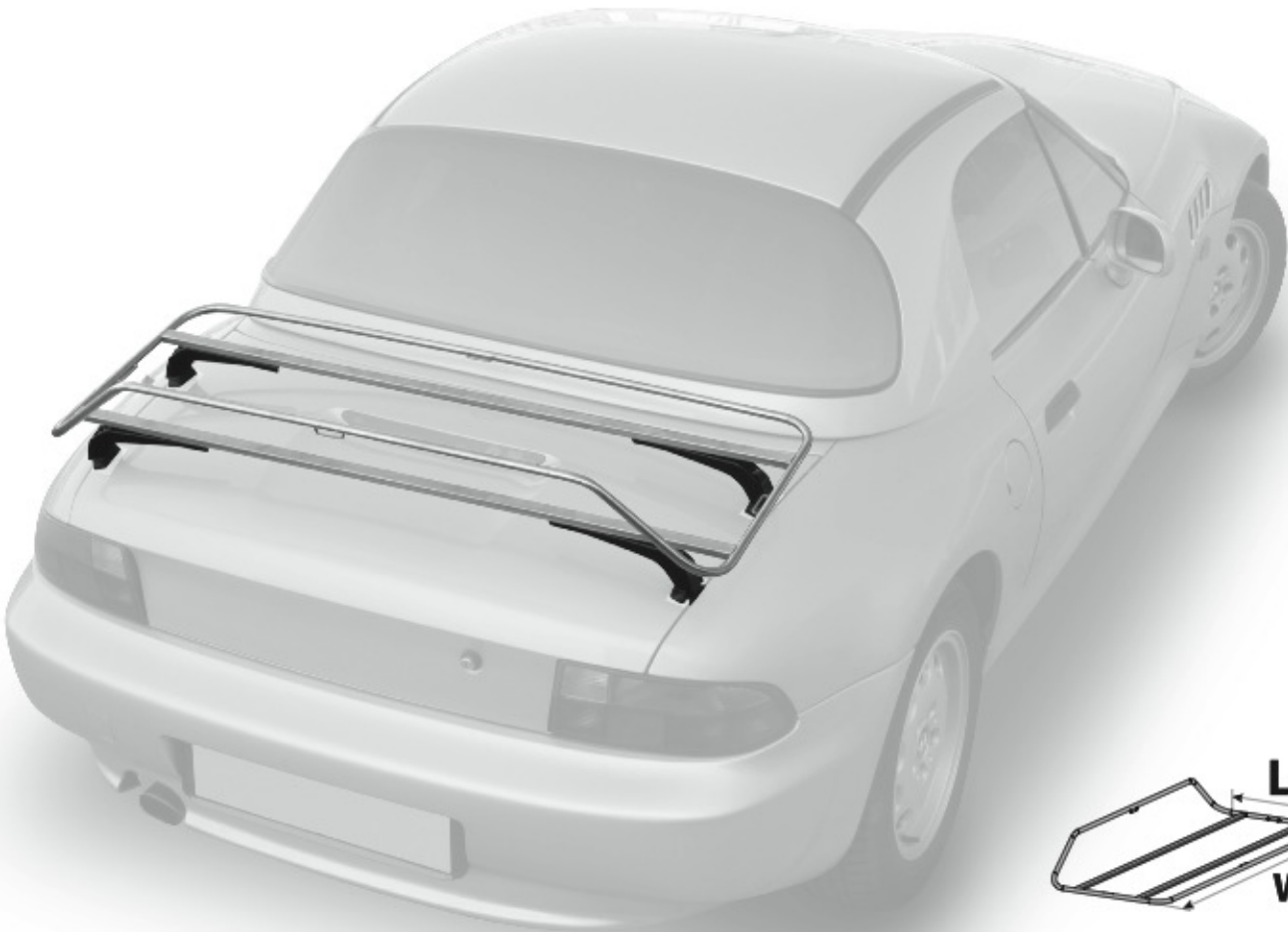

MAX
20KG

Art.		W	L
N70011	RR-1	97cm	45cm
N70012	RR-2	117cm	50cm
N70013	RR-3	128cm	50cm

(I) ISTRUZIONI DI MONTAGGIO
(GB) FITTING INSTRUCTIONS
(D) MONTAGEANLEITUNG
(F) INSTRUCTIONS DE MONTAGE
(E) INSTRUCCIONES DE MONTAJE
(P) INSTRUÇÕES DE MONTAGEM
(NL) MONTAGE-INSTRUCTIES
(S) MONTERINGSANVISNING

(FIN) ASENNUSOHJE
(EST) PAIGALDUSJUHEND
(LAT) STIPRINĀŠANAS INSTRUKCIJA
(LT) PRITVIRTINIMO INSTRUKCIJOS
(PL) INSTRUKCJA MONTAŻU
(RUS) Инструкции по установке
(CZ) NÁVOD NA MONTÁŽ
(SK) NÁVOD NA MONTÁŽ

(SLO) NAVODILA ZA PRITRJEVANJE
(HR) UPUTA ZA SASTAVLJANJE
(H) A FELSZERELÉS MÓDJA
(GR) Οδηγία συναρμολόγησης
(TR) MONTAJ TALIMATLARL
(BG) ИНСТРУКЦИИ ЗА МОНТАЖ
(SRB) UPUTSTVA ZA MONTAŽU

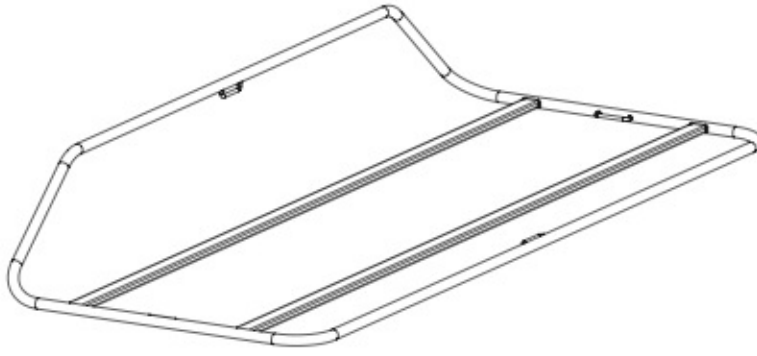
x1**W****L**11AX0001 **97cm** x **45cm**11AX0002 **117cm** x **50cm**11AX0003 **128cm** x **50cm****x4****A**

76FE0004

x4**B**

78FE0008

x4**C**

00GO0179

x4**D**

40FE0207

x4**E**

77PL0001

x4**F**

77PL0002

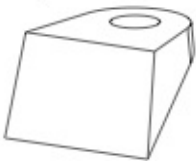
x1**MANUAL****x4****G**

82PL0001

x816
mm**H**M6x16
60CE6016**x4**30
mm**I**M6x30
60CE6030**x12****J**

61FN0612

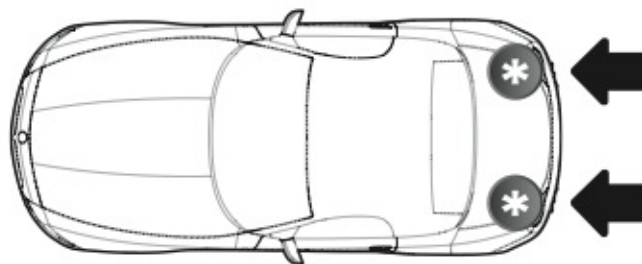
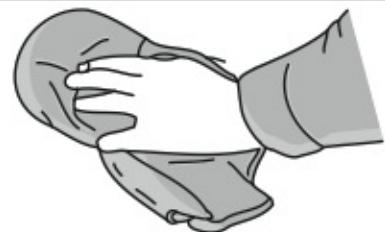
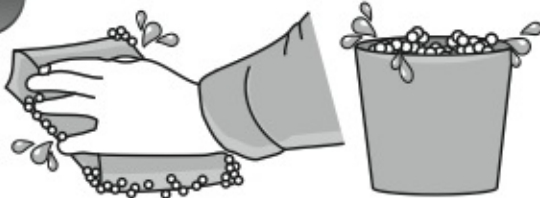
x4**K**77PL0003
ADHESIVE*****

5

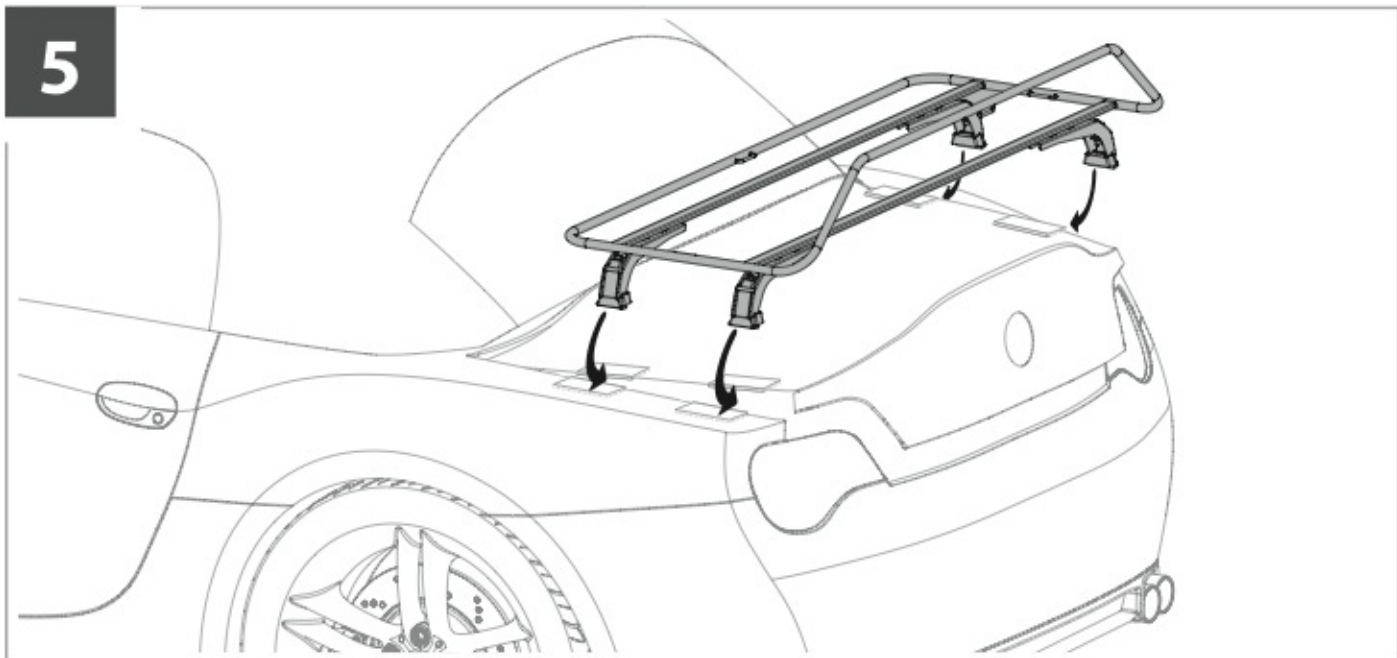

6

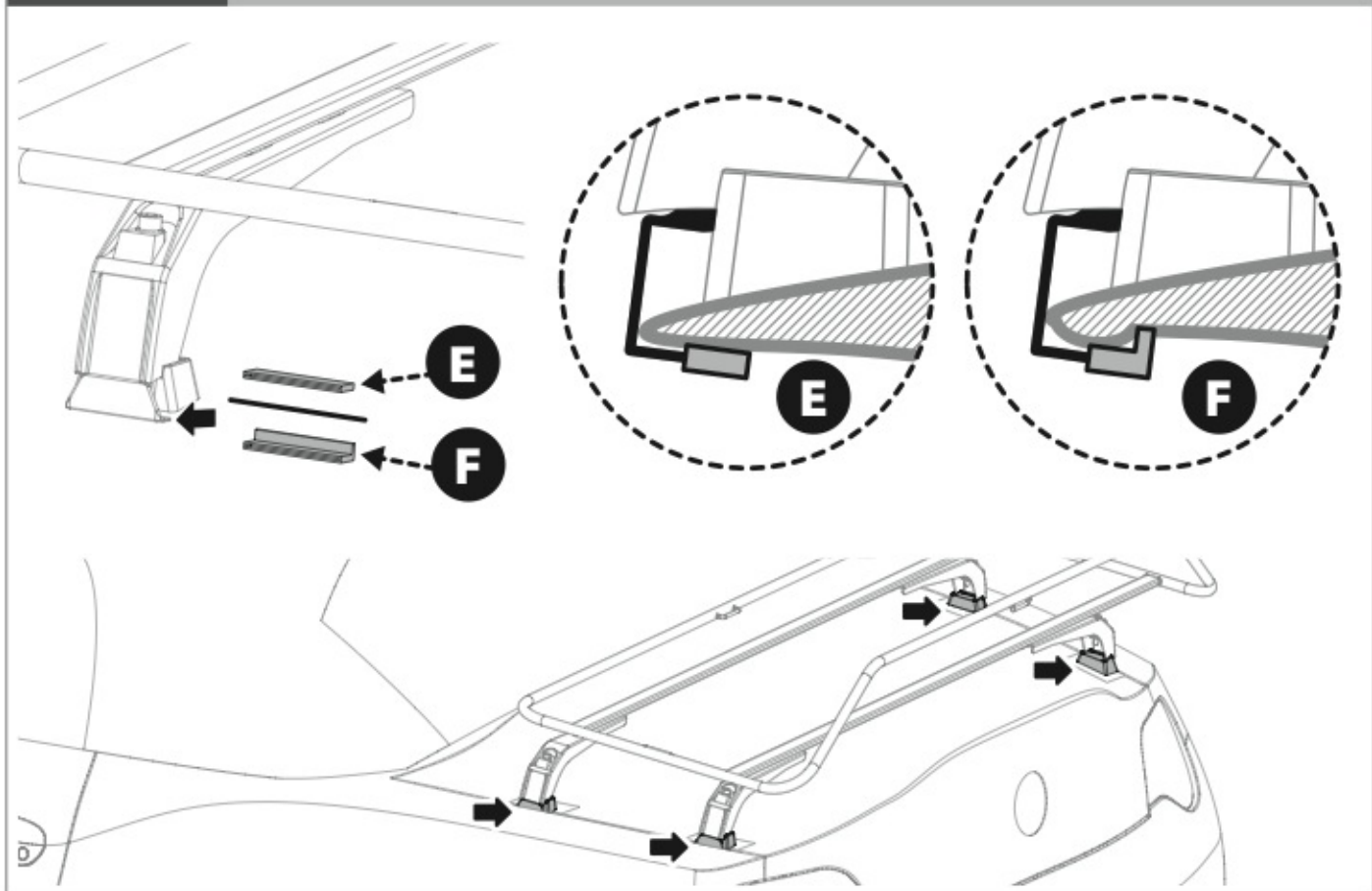
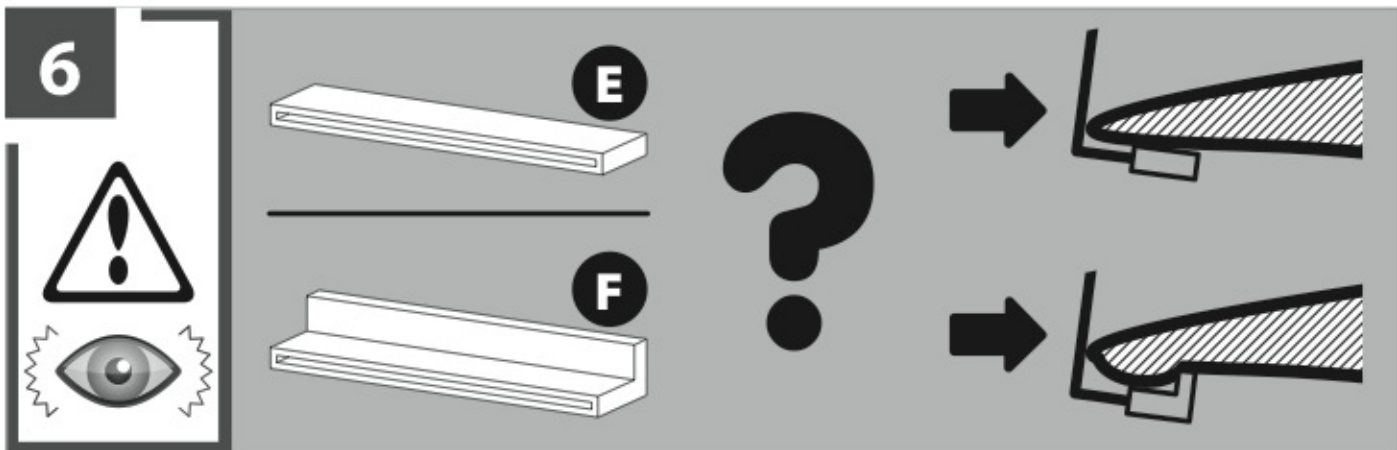

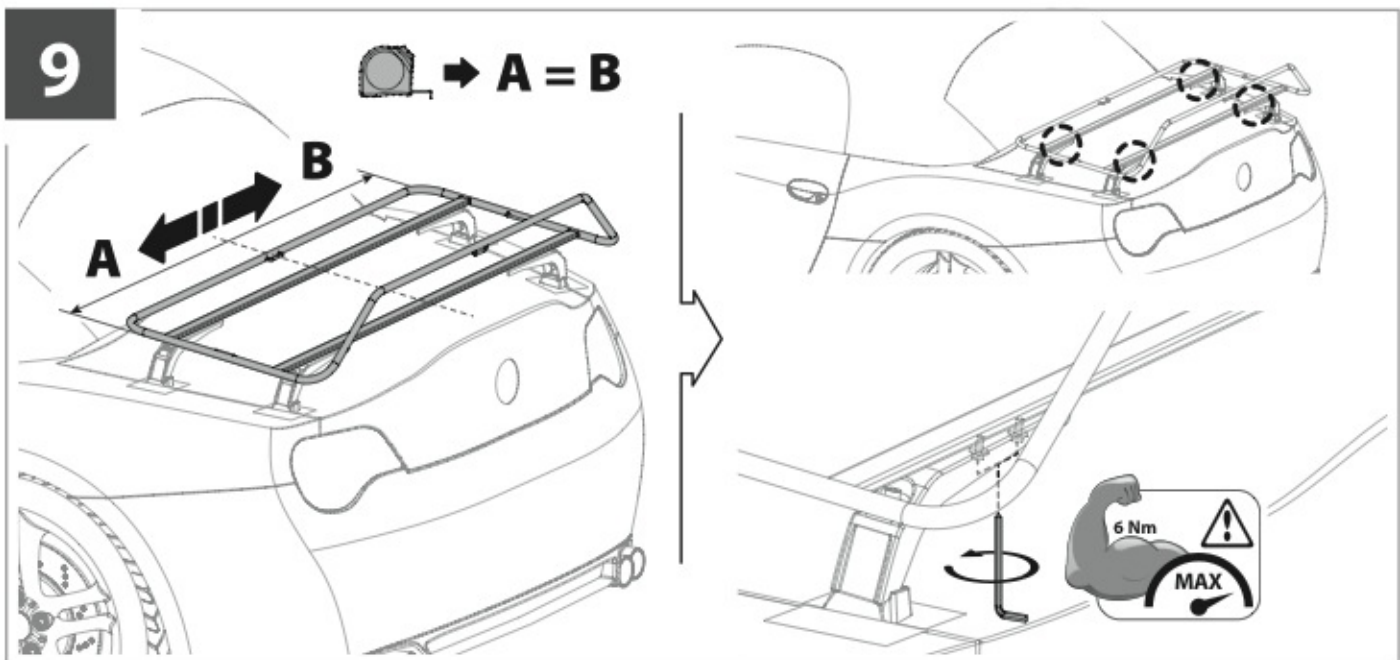
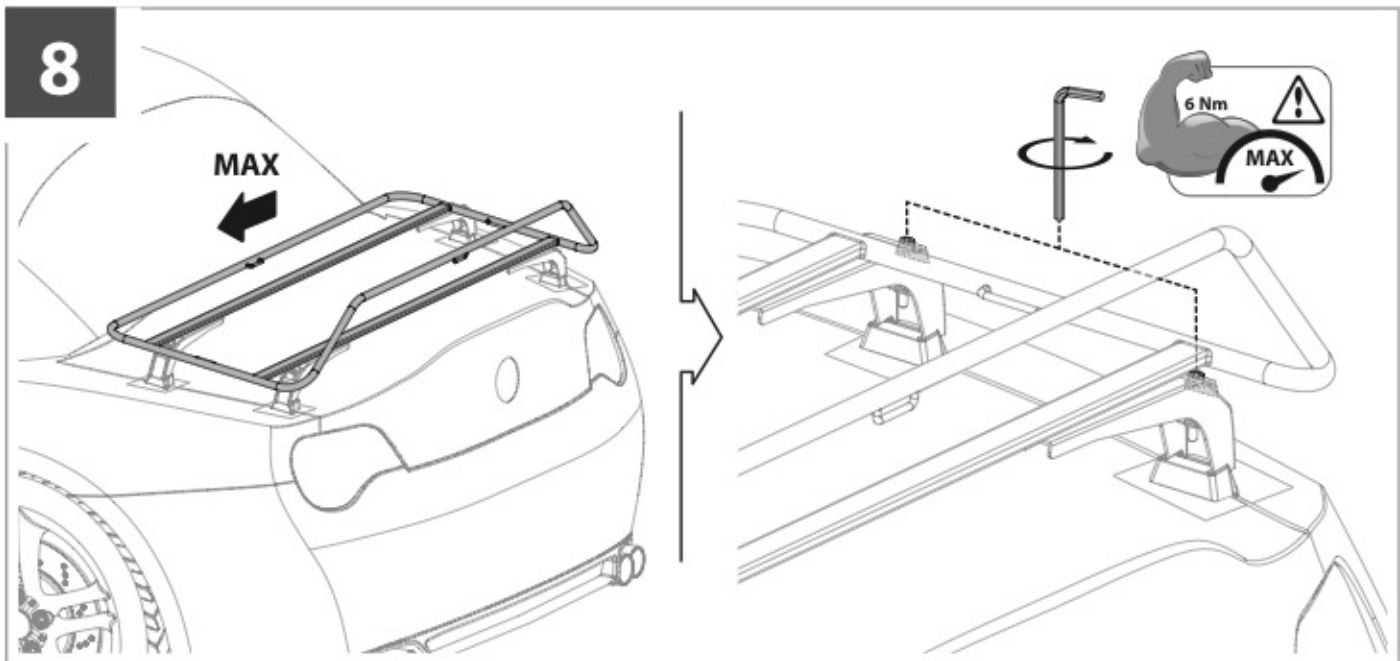
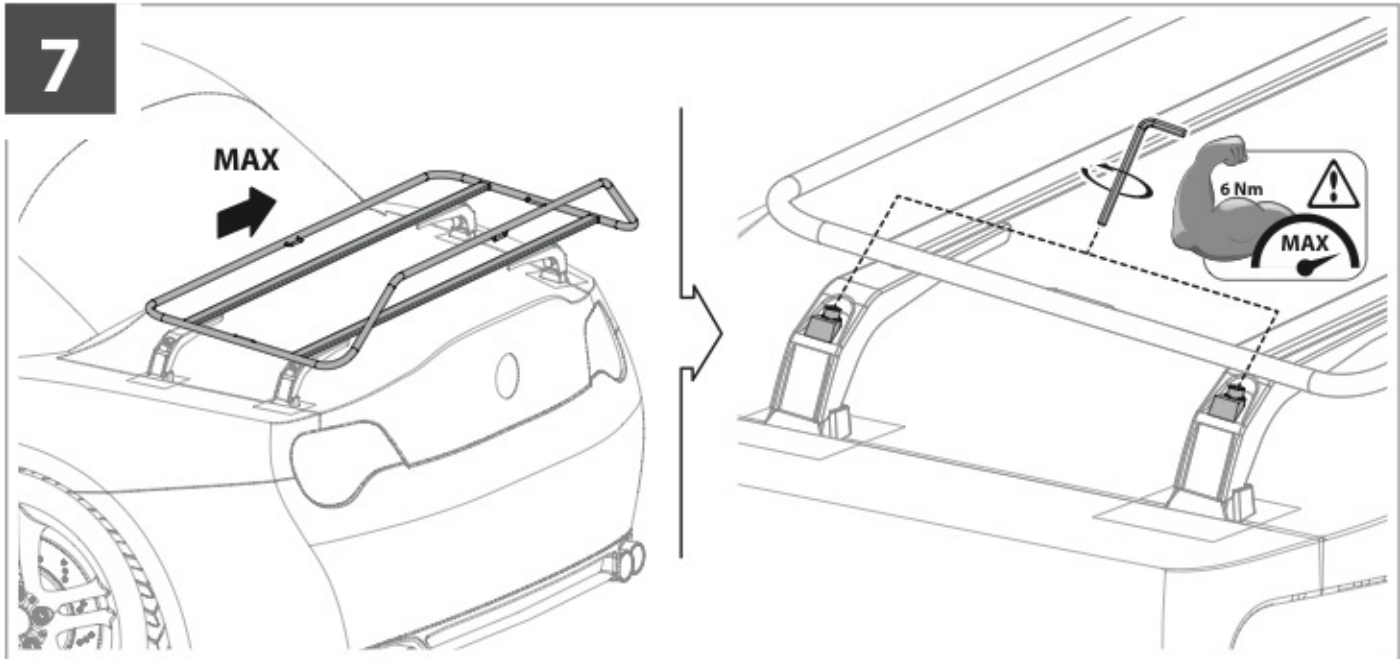

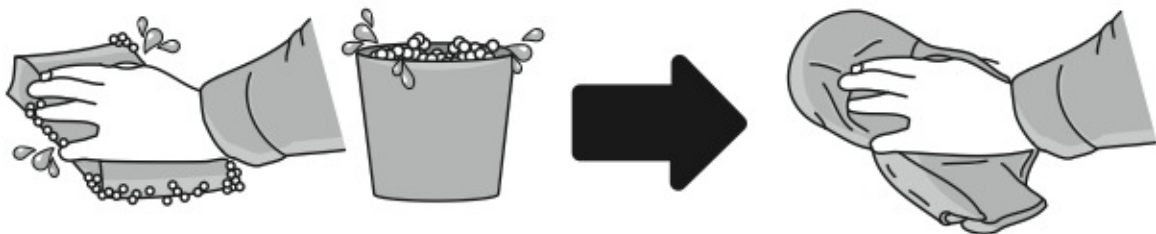
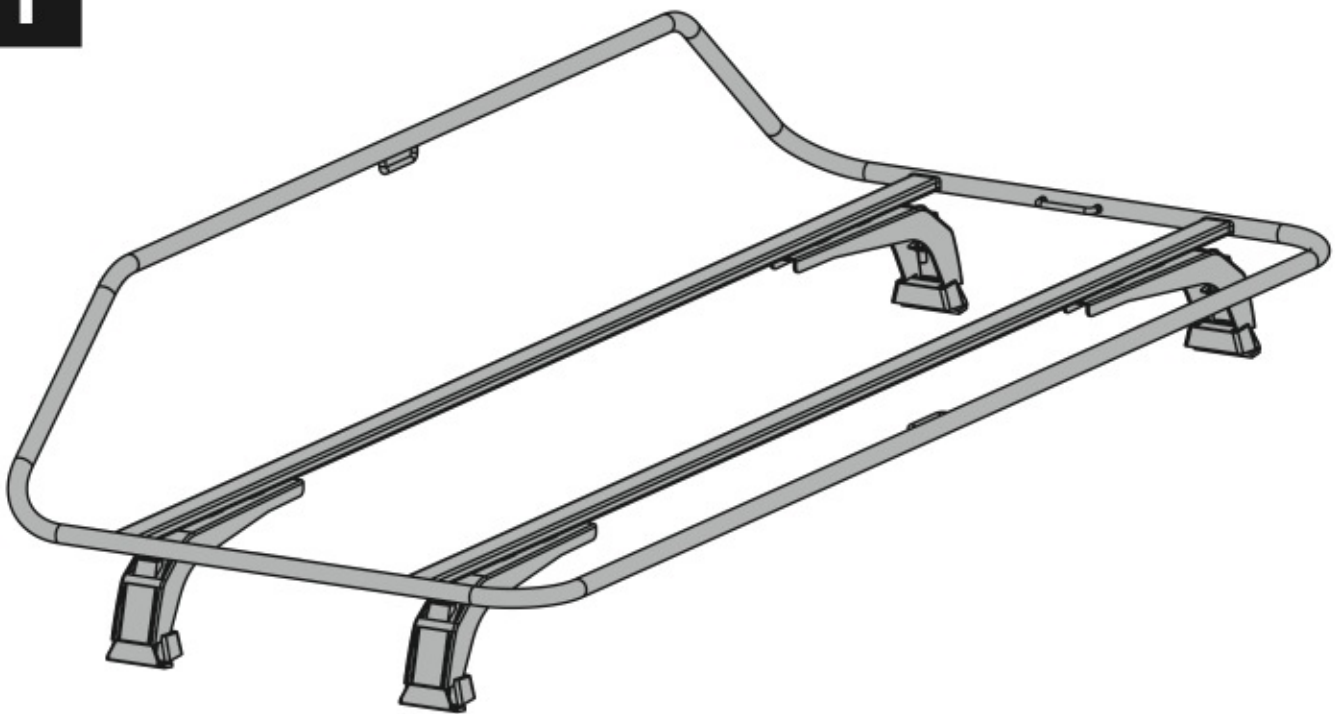

- ⓘ Manutenzione parti in plastica e parti in gomma: lavare le parti in plastica / gomma esclusivamente con acqua e sapone, non usare assolutamente dei solventi. Asciugare e proteggere le parti con prodotti a base di silicone
- ⓖB Maintenance of parts in plastic and rubber: wash the part in plastic or rubber using only soap and water and never use solvents. Dry and protect the parts using silicone based agents
- ⓕ Entretien des pièces en plastique et en caoutchouc: laver les pièces en plastique / caoutchouc qu'à l'eau chaude et au savon, ne pas utiliser de solvants. Essuyer et protéger les pièces au moyen de produits à base de silicone
- ⓓ Instandhaltung von Kunststoff- und Gummiteilen: Die Teile aus Kunststoff and Gummi nur mit Seifenwasser waschen, auf keinen Fall Lösungsmittel verwenden. Die Teile trocknen und mit silikonhaltigen Schutzmitteln konservieren
- ⓔ Mantenimiento de las piezas de plástico y de las piezas de goma: lave las piezas de plástico / goma exclusivamente con agua y jabón; no use nunca solventes. Seque y proteja las piezas con productos a base de siliconas



ATTENZIONE WARNING

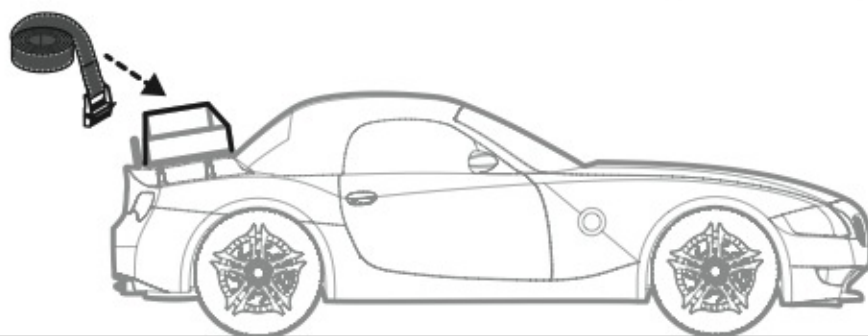
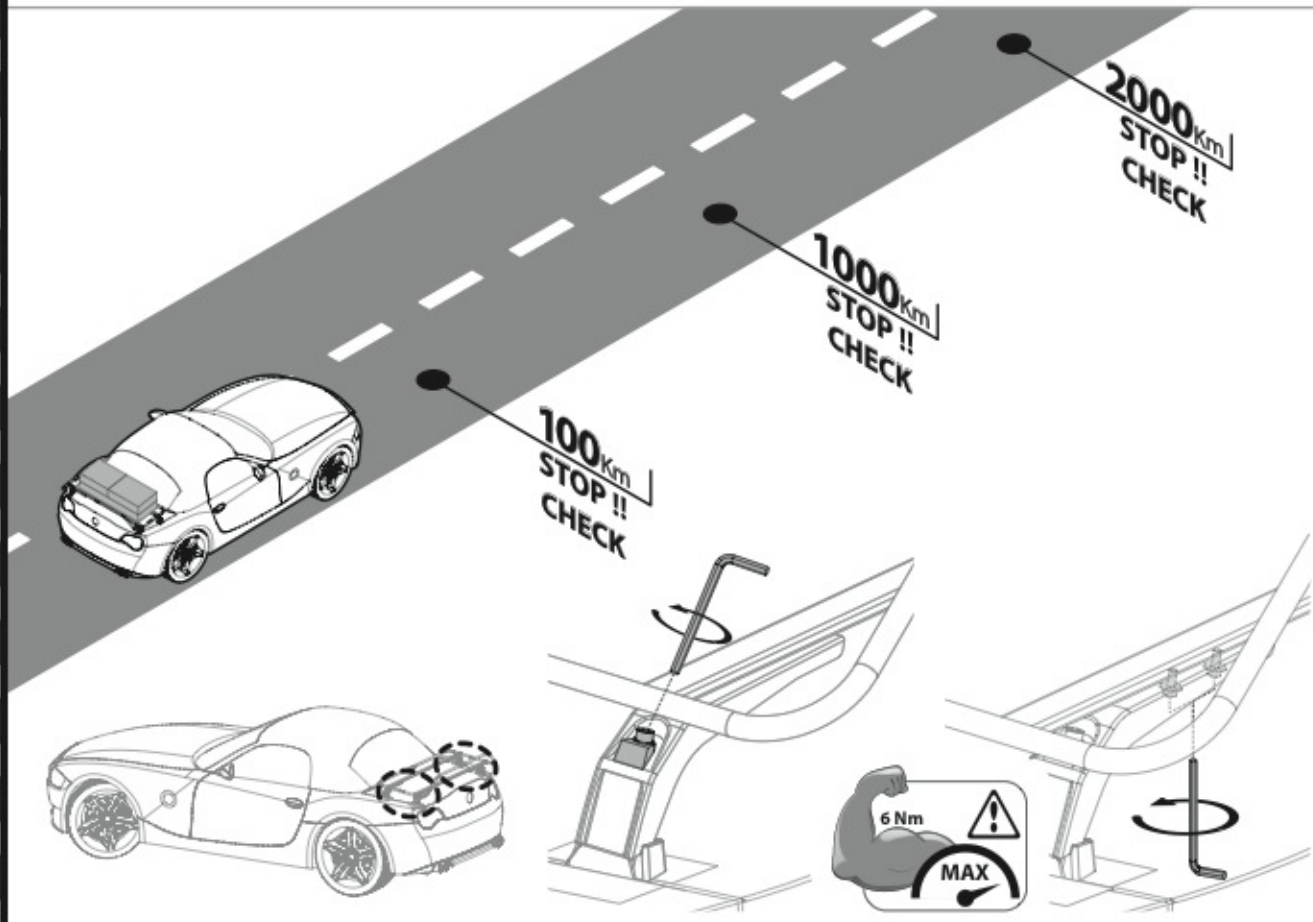

Ⓛ Il carico deve essere saldamente fissato alle barre con appositi nastri tensori o corde. Non devono essere assolutamente utilizzate corde elastiche

Ⓜ Loads must be tightly fastened to bars with the use of appropriate tie belts or cords. Do not use elastic ropes

Ⓟ Le chargement doit être solidement fixé aux barres à l'aide de cordes ou de bandes de tension prévues à cet effet. Ne jamais utiliser de cordes élastiques

Ⓡ Die Last muss mit Hilfe von entsprechenden Spanngurten oder Seilen an den Stangen befestigt werden. Es dürfen auf keinen Fall elastische Seile verwendet werden!

Ⓢ La carga debe fijarse bien a las barras con cintas especiales de tensión o con cuerdas. No se debe utilizar nunca cuerdas elásticas

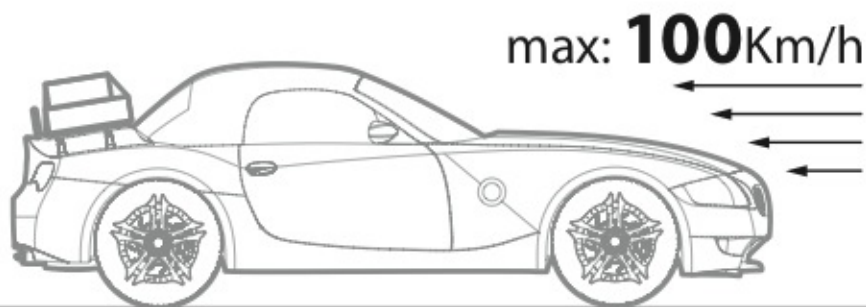

NORDRIVE®

TRANSPORT SOLUTIONS

www.nordrive.it

is a registered trade mark of
LAMPA S.p.A.
46019 Viadana (MN) ITALY
Ditta certificata UNI EN ISO 9001:2008
www.lampa.it